

DESCRIPTION

The UC284x and UC384x are fixed frequency current mode PWM controller. They are specially designed for OFF Line and DC to DC converter applications with a minimal external components. Internally implemented circuits include a trimmed oscillator for precise duty cycle control, a temperature compensated reference, high gain error amplifier, current sensing comparator, and a high current totem pole output ideally suited for driving a power MOSFET. Protection circuitry includes built under voltage lockout and current limiting.

The UC2842/44, UC3842/44 have UVLO thresholds of 16 V (on) and 10 V (off). The corresponding thresholds for the UC2843/44, UC3843/45 are 8.4V (on) and 7.6V (off).

The UC2842/43, UC3842/43 can operate within 100% duty cycle.

The UC2844/45, UC3844/45 can operate within 50% duty cycle.

The UC2842/43/44/45 is characterized for operation from TA=40°C to 85°C.

The UC3842/43/44/45 is characterized for operation from TA=0°C to 70°C.

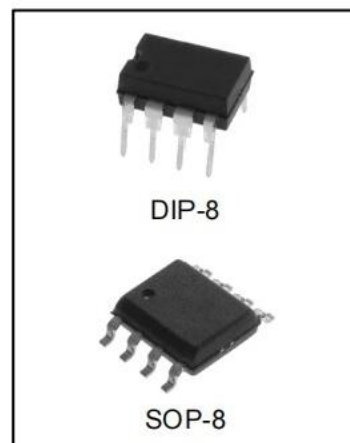

DIP-8

SOP-8

FEATURES

- Low Start-Up and Operating Current
- High Current Totem Pole Output
- Under voltage Lockout With Hysteresis
- Operating Frequency Up To 500KHz

Order Information

DEVICE	Package Type	MARKING	Packing	Packing Qty
UC2842N	DIP-8	UC2842	TUBE	2000/box
UC2843N	DIP-8	UC2843	TUBE	2000/box
UC2844N	DIP-8	UC2844	TUBE	2000/box
UC2845N	DIP-8	UC2845	TUBE	2000/box
UC2842M/TR	SOP-8	UC2842	REEL	2500/reel
UC2843M/TR	SOP-8	UC2843	REEL	2500/reel
UC2844M/TR	SOP-8	UC2844	REEL	2500/reel
UC2845M/TR	SOP-8	UC2845	REEL	2500/reel
UC3842N	DIP-8	UC3842	TUBE	2000/box
UC3843N	DIP-8	UC3843	TUBE	2000/box
UC3844N	DIP-8	UC3844	TUBE	2000/box
UC3845N	DIP-8	UC3845	TUBE	2000/box
UC3842M/TR	SOP-8	UC3842	REEL	2500/reel
UC3843M/TR	SOP-8	UC3843	REEL	2500/reel
UC3844M/TR	SOP-8	UC3844	REEL	2500/reel
UC3845M/TR	SOP-8	UC3845	REEL	2500/reel

Pin CONNECTION

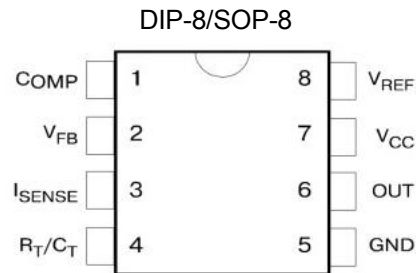

PIN FUNCTION

N	FUNCTION	DESCRIPTION
1	COMP	This pin is the Error Amplifier output and is made for loop compensation.
2	VFB	This is the inverting input of the Error Amplifier. It is normally connected to the switching power supply output through a resistor divider.
3	ISENSE	A voltage proportional to inductor current is connected to this input. The PWM uses this information to terminate the output switch conduction.
4	Rr/Cr	The oscillator frequency and maximum Output duty cycle are programmed by connecting resistor Rr to Vref and capacitor Cr to ground.
5	GROUND	This pin is the combined control circuitry and power ground.
6	OUTPUT	This output directly drives the gate of a power MOSFET. Peak currents up to 1A are sourced and sink by this pin.
7	VCC	This pin is the positive supply of the integrated circuit.
8	Vref	This is the reference output. It provides charging current for capacitor Cr through resistor Rr.

BLOCK DIAGRAM

(toggle flip flop used only in UC2844/45, UC3844/45)

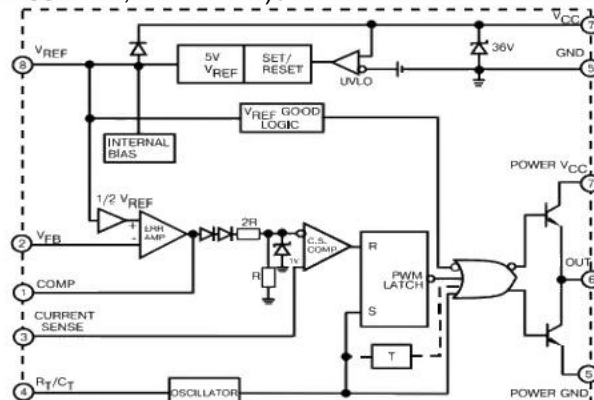

Absolute Maximum Ratings

Characteristic	Symbol	Value	Unit
Supply Voltage (low impedance source)	VCC	30	V
Output Current	Io	1	A
Input Voltage (Analog Inputs pins 2,3)	Vi	0.3 to 5.5	V
Error Amp Output Sink Current	ISINK (E.A)	10	mA
Power Dissipation (TA=25°C)	Po	1	W
Storage Temperature Range	Tstg	-65 to 150	°C
Lead Temperature (Soldering, 10 seconds)	TL	245	°C

Absolute Maximum Ratings indicate limits beyond which damage to the device may occur. Operating Ratings indicate conditions for which the device is intended to be functional, but specific performance is not ensured.

Electrical characteristics (*VCC=15V, RT=10k, CT=3.3nF, TA=0C to+70°C, unless otherwise specified)

Characteristics	Symbol	Test Condition	Min	Typ	Max	Unit
Reference Section						
Reference Output Voltage	VREF	TJ=25°C, IREF =1 mA	4.9	5.0	5.1	V
Line Regulation	AVREF	12V≤Vcc≤25V		6.0	20	mV
Load Regulation	AVREF	1 mA≤IREF≤20mA		6.0	25	
Short Circuit Output Current	ISC	TA=25°C		-100	-180	mA
Oscillator Section						
Oscillation Frequency	f	TJ=25°C	47	52	57	KHz
Frequency Change with Voltage	Af/AVcc	12V≤Vcc≤25V		0.05	1.0	%
Oscillator Amplitude	V(OSC)	(peak to peak)		1.6		V
Error Amplifier Section						
Input Bias Current	IBIAS	VrB=3V		-0.1	-2	μA
Input Voltage	VI(E.A)	Vpin1=2.5V	2.42	2.5	2.58	V
Open Loop Voltage Gain	AVOL	2V≤Vo≤4V	65	90		dB
Unity Gain Bandwidth	UGBW	Tj=25°C, Note 3	0.5	0.6		MHz
Power Supply Rejection Ratio	PSRR	12V≤Vcc≤25 V	60	70		dB
Output Sink Current	ISINK	Vpin2=2.7V, Vpint=1.1V	2	7		mA
Output Source Current	ISOURCE	Vpin2=2.3V, Vpin1=5V	-0.5	-1.0		mA
High Output Voltage	VOH	Vpin2=2.3V, RL=15KQ to GND	5.0	6.0		V
Low Output Voltage	VOL	Vpin2=2.7V, RL=15KQ to PIN 8		0.8	1.1	
Current Sense Section						
Gain	Gy	(Note 1 &2)	2.85	3.0	3.15	V/V
Maximum Input Signal	VI(MAX)	V pint=5V(Note1)	0.9	1.0	1.1	V
Supply Voltage Rejection	SVR	12V≤Vcc≤25V(Note 1)		70		dB
Input Bias Current	IBIAS	Vpin3=3V		-3.0	-10	μA
Output Section						
Low Output Voltage	VOL	IsiNk =20 mA		0.08	0.4	V
		IsiNk =200 mA		1.4	2.2	
High Output Voltage	VOH	IsiNk =20 mA	13	13.5		
		IsiNk =200 mA	12	13.0		
Rise Time	tr	TJ=25°C, CL=1nF (Note 3)		45	150	nS
Fall Time	tr	TJ=25°C, CL=1nF (Note 3)		35	150	
Undervoltage Lockout Section						
Start Theshold	VTH(ST)	UC2842/44, UC3842/44	14.5	16.0	17.5	V
		UC2843/45, UC3843/45	7.8	8.4	9.0	
Min. Operating Voltage (After Turn On)	VOPR(min)	UC2842/44, UC3842/44	8.5	10	11.5	V
		UC2843/45, UC3843/45	7.0	7.6	8.2	
PWM Section						
Max. Duty Cycle	D(MAX)	UC2842/43, UC3842/43	95	97	100	%
		UC2844/45, UC3844/45	47	48	50	
Min. Duty Cycle	D(MAX)			0		
Total Standby Current						
Start Up Current Operating Supply Current	IST ICC(OPR)	UC3842/43/44/45		0.17	0.3	mA
		Vpin3 =Vpin2 =0V		13	17	
Zener Voltage	Vz	cc=25 mA	30	38		V

*Adjust VCC above the start threshold before setting it to 15V.

Note 1: Parameter measured at trip point of latch with Vpin2=0.

 Note 2: Gain defined as $A = \Delta V_{pin1} / \Delta V_{pin3}$; $0 \leq V_{pin3} \leq 0.8V$.

Note 3: These parameters, although guaranteed, are not 100% tested in production.

APPLICATION INFORMATION

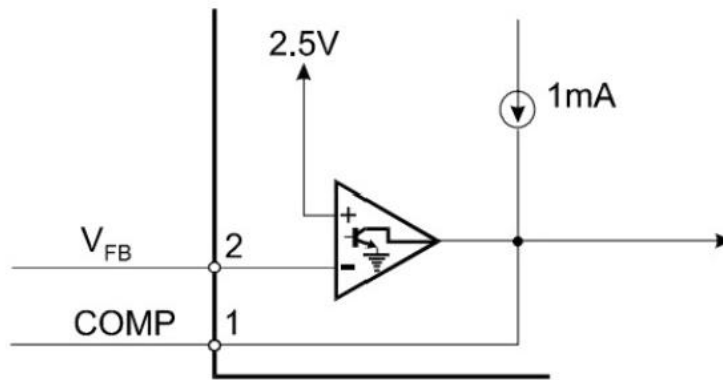
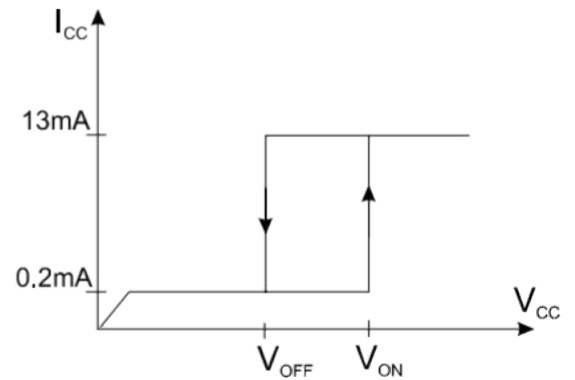
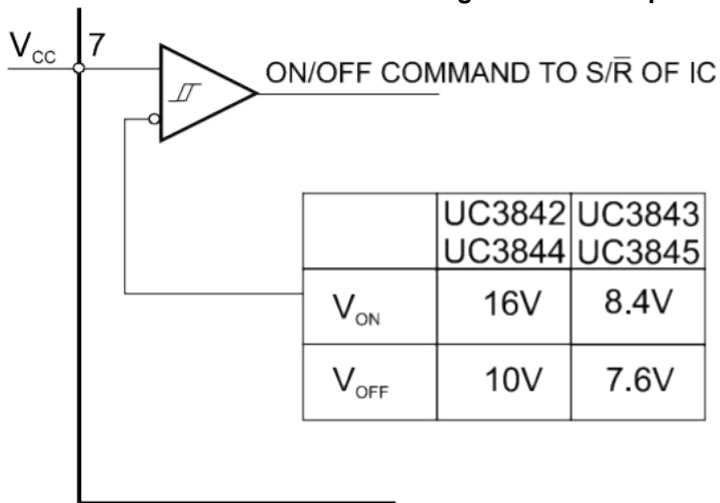

Figure 1. Error Amp Configuration



During UVLO, the Output is low

Figure 2. Under voltage Lockout

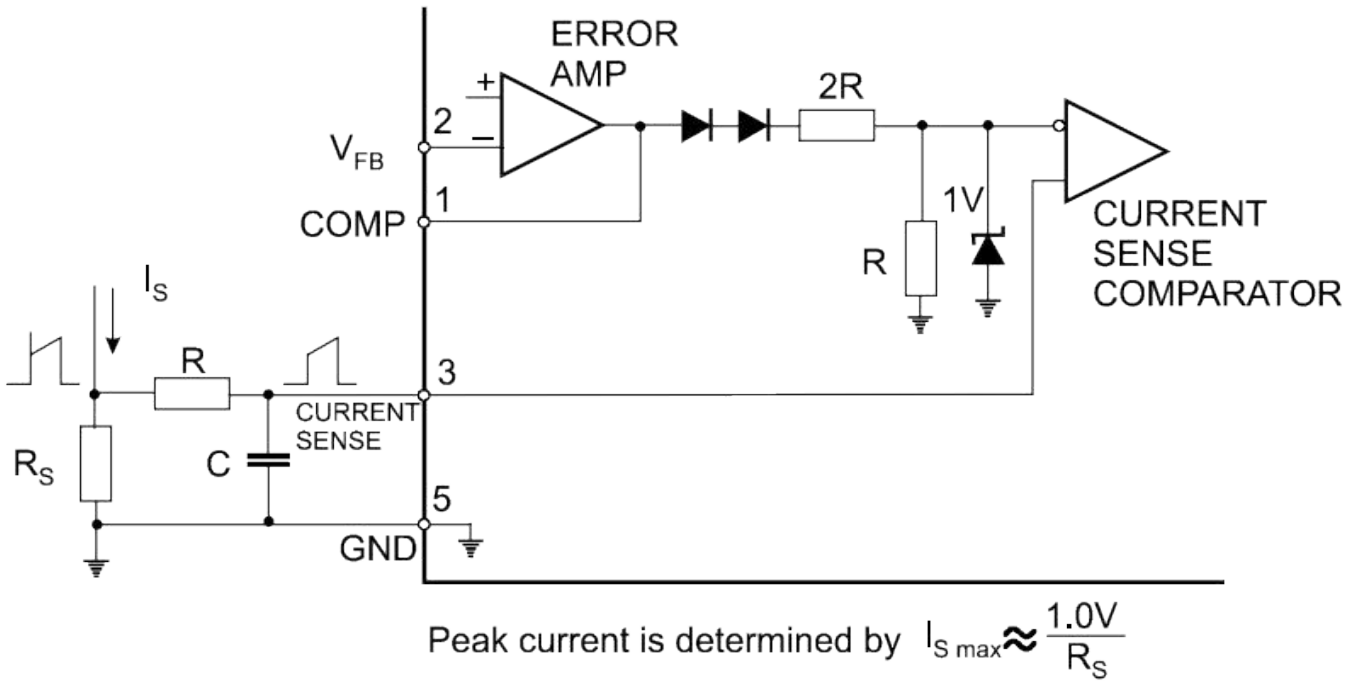

Figure 3. Current Sense Circuit

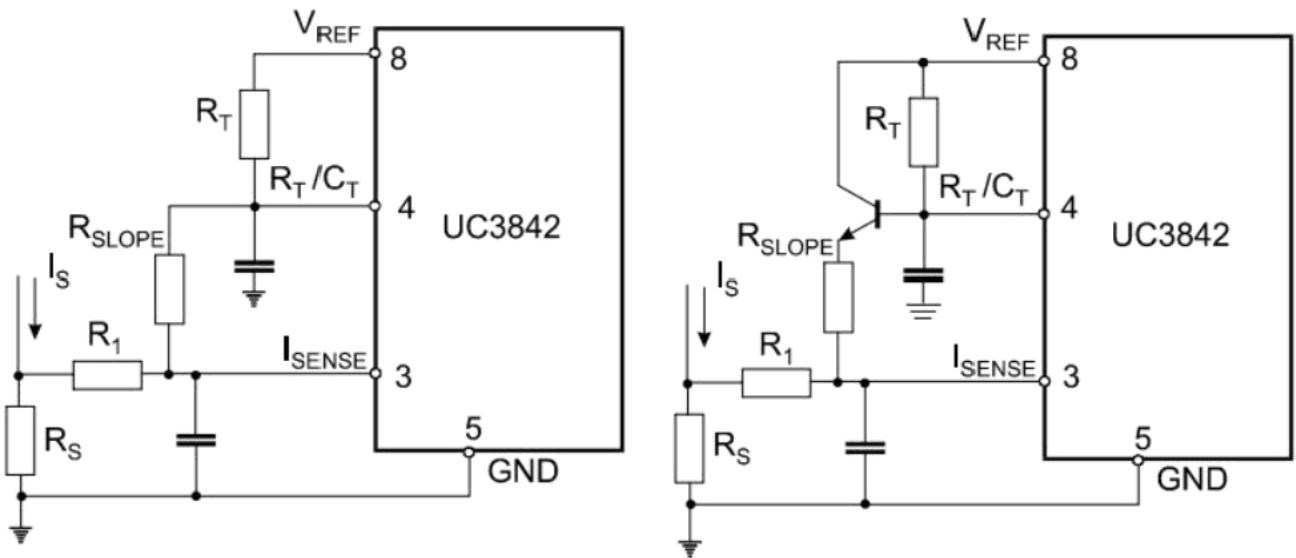
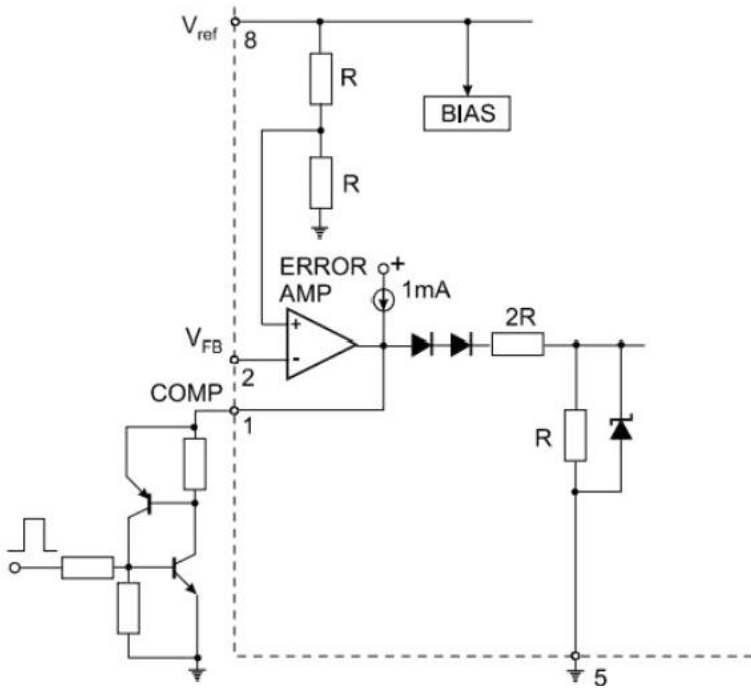
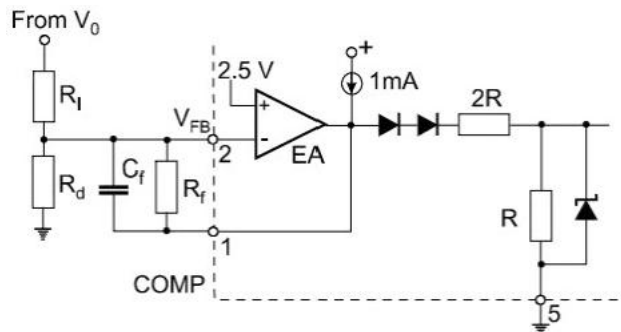

Figure 4. Slope Compensation Techniques



SCR must be selected for a holding current of less than 0.5mA.
The simple two transistor circuit can be used in place of the SCR as shown.

Figure 5.Latched Shutdown



Error Amp compensation circuit for stabilizing any current-mode topology except for boost and flyback converters operating with continuous inductor current.

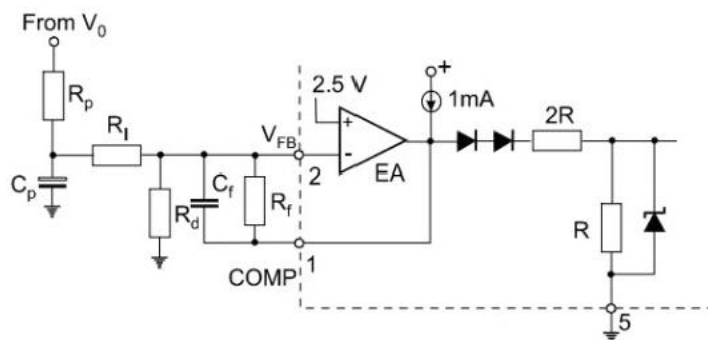

Error Amp compensation circuit for stabilizing current-mode boost and flyback topologies operating with continuous inductor current.

Figure 6.Error Amplifier Compensation

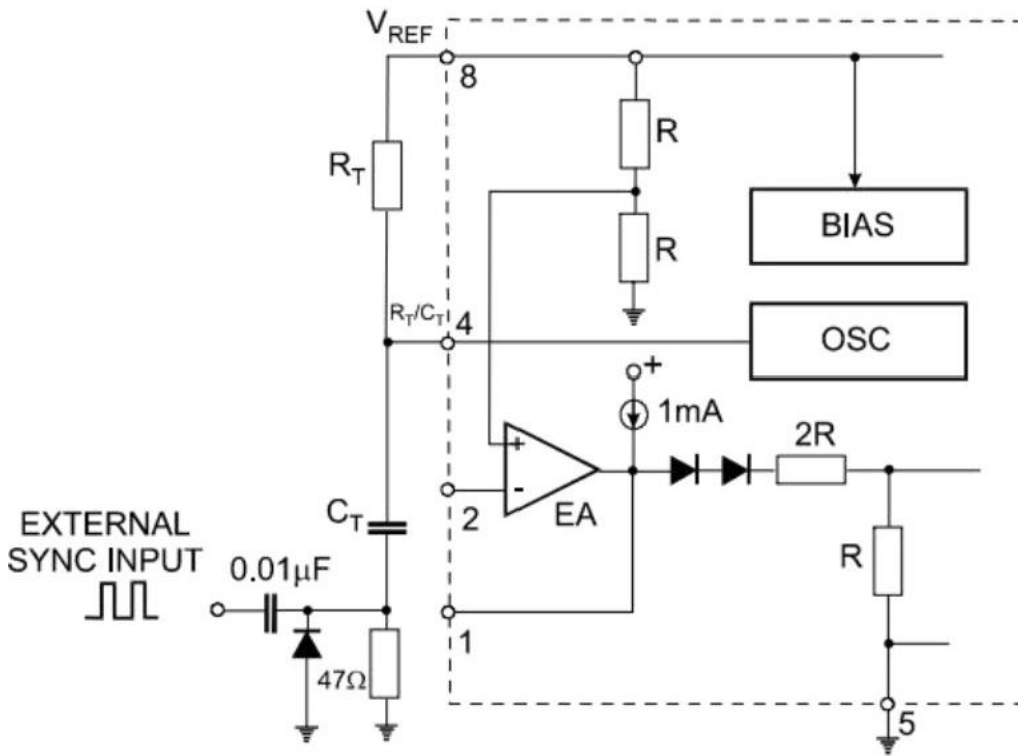

Figure 7. External Clock Synchronization

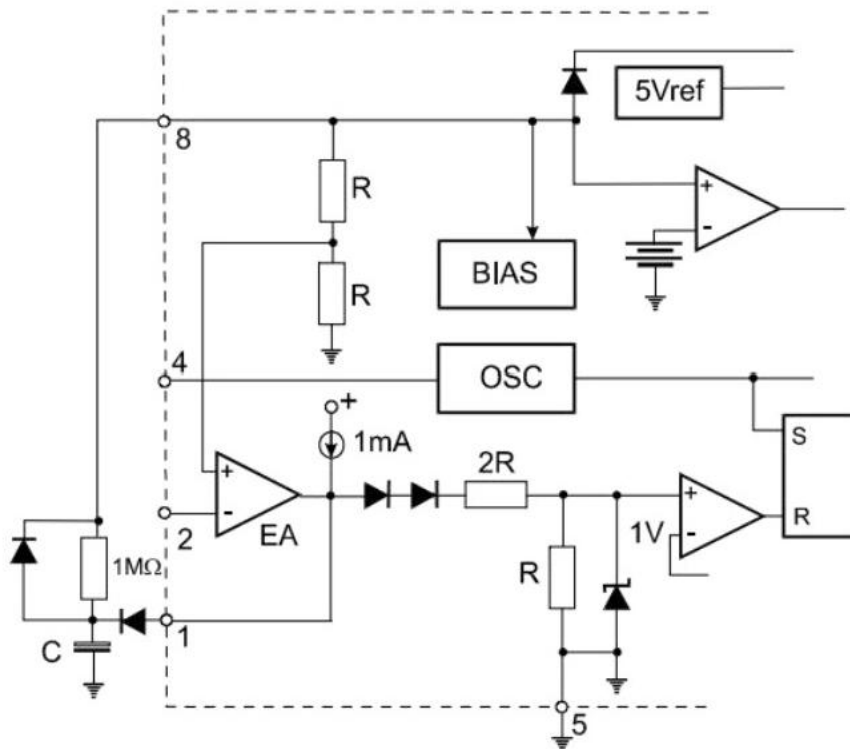

Figure 8. Soft-Start Circuit

TYPICAL PERFORMANCE CHARACTERISTICS

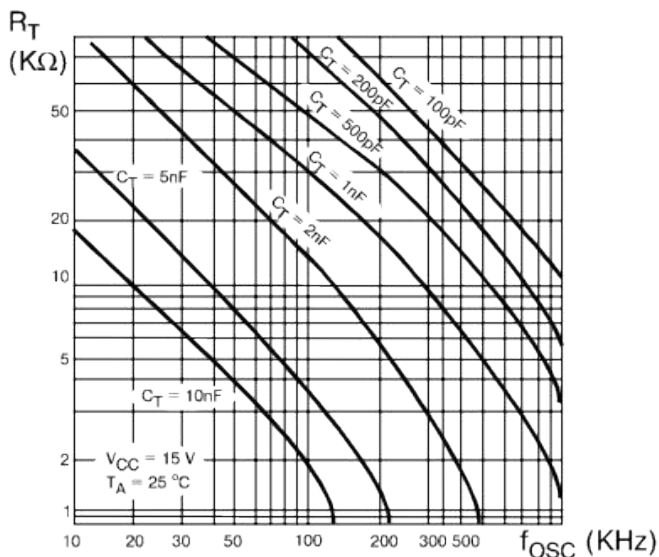

Figure 1. Timing Resistor vs. Oscillator Frequency

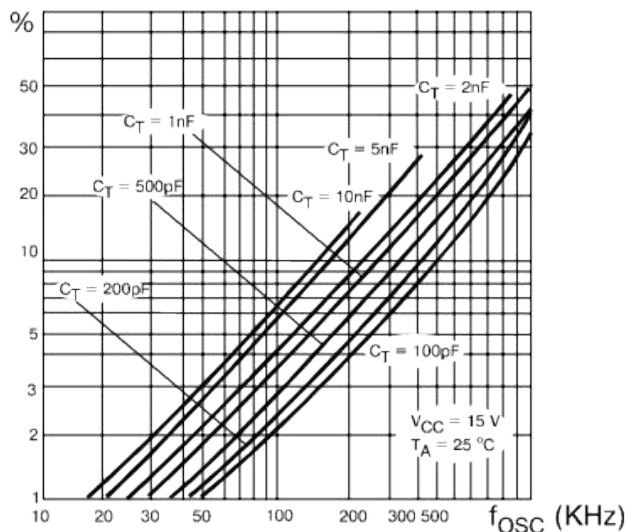

Figure 2. Output Dead-Time vs. Oscillator Frequency

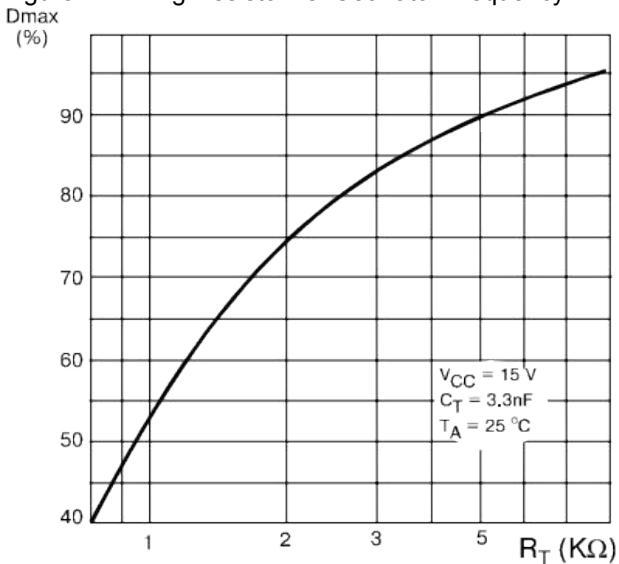

Figure 3. Maximum Output Duty Cycle vs. Timing Resistor (UC3842/43)

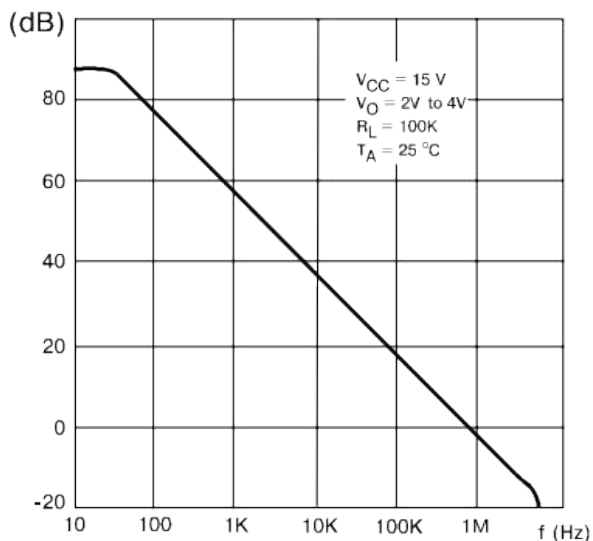

Figure 4. Error Amp Open-Loop Gain vs. Frequency

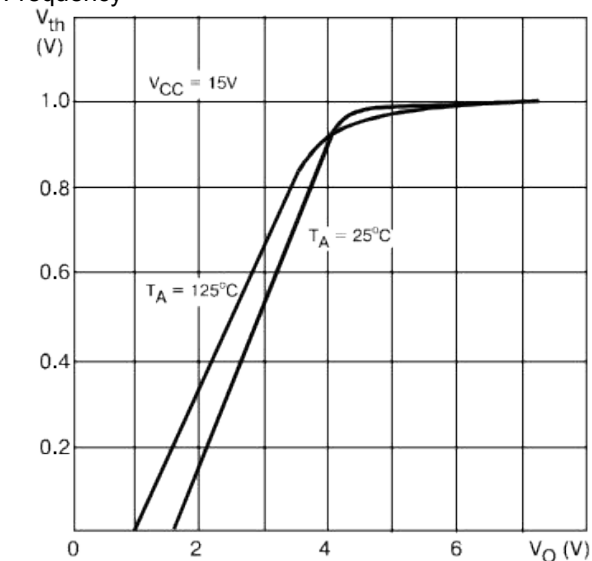

Figure 5. Current Sense Input Threshold vs. Error Amp Output Voltage

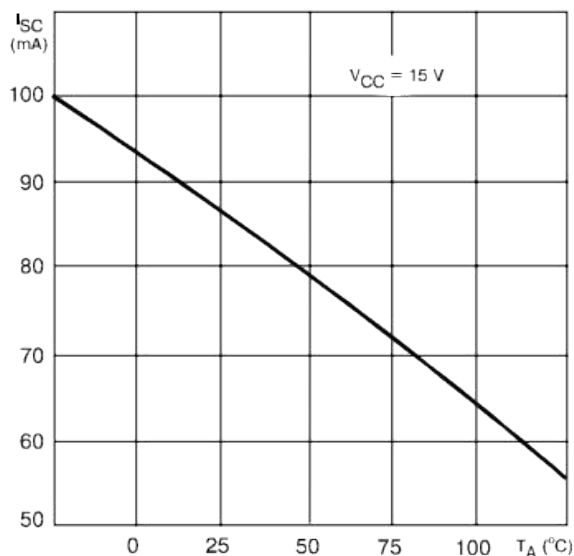

Figure 6. Reference Short Circuit Current vs. Temperature

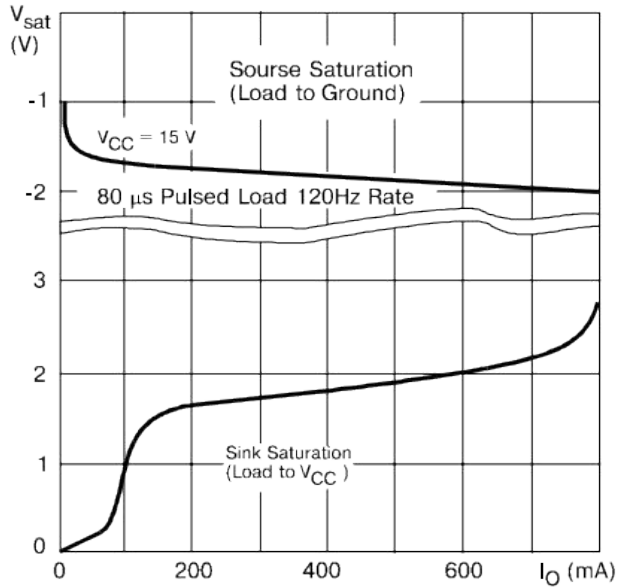

Figure 7. Output Saturation Voltage vs. Load Current
TA = 25°C

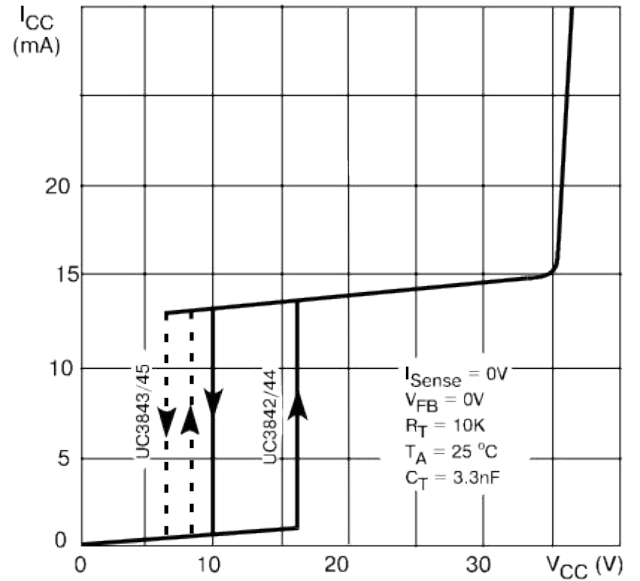

Figure 8. Supply Current vs. Supply Voltage

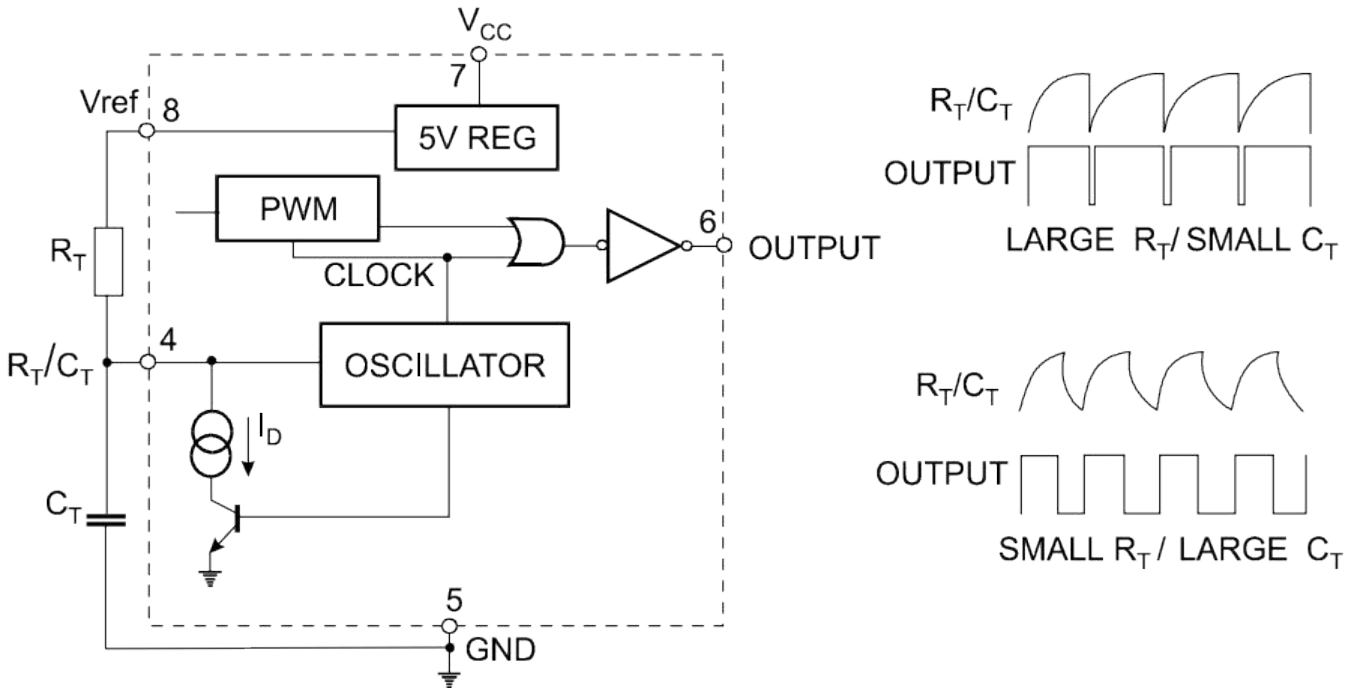
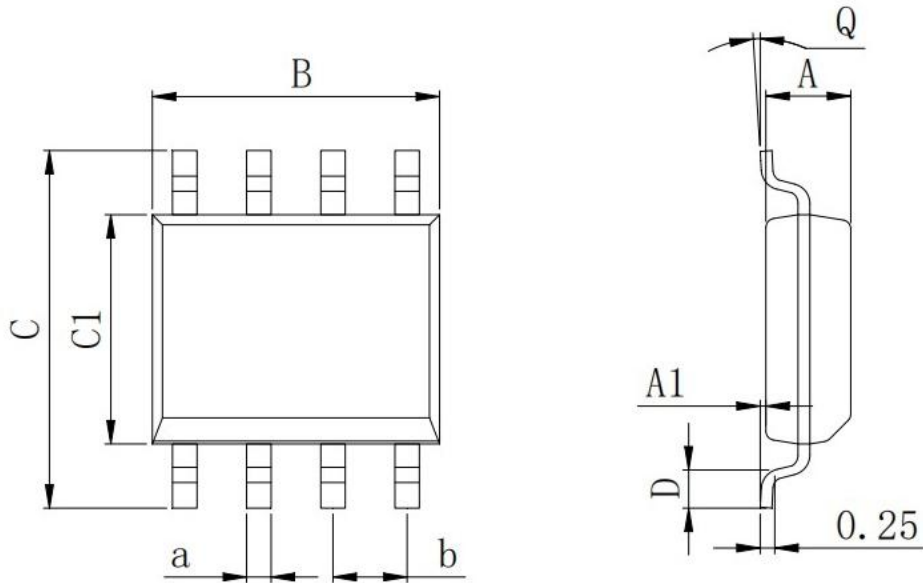

Figure 9. Oscillator and Output Waveforms

Physical Dimensions

SOP-8



Dimensions In Millimeters(SOP-8)									
Symbol:	A	A1	B	C	C1	D	Q	a	b
Min:	1.35	0.05	4.90	5.80	3.80	0.40	0°	0.35	1.27 BSC
Max:	1.55	0.20	5.10	6.20	4.00	0.80	8°	0.45	

DIP-8

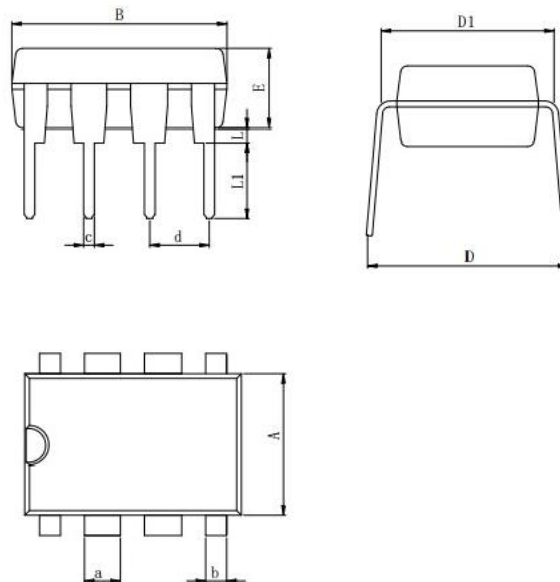

Dimensions In Millimeters(DIP-8)											
Symbol:	A	B	D	D1	E	L	L1	a	b	C	d
Min:	6.10	9.00	8.10	7.42	3.10	0.50	3.00	1.50	0.85	0.40	2.54 BSC
Max:	6.68	9.50	10.9	7.82	3.55	0.70	3.60	1.55	0.90	0.50	